

# Precast Concrete Manhole (96" ID) Storm Sewer (Flat Top)

## SPECIFICATIONS:

ASTM C478  
 Concrete: 4000 PSI (Min.)  
 Approx. Wt./LinFt: 3090 Lbs.  
 Joint O-Ring Gasket  
 Steel: Grade 60

Openings for inlets & outlets are made 4 inches larger in diameter than the outside diameter of the pipe & are located as required per plans.

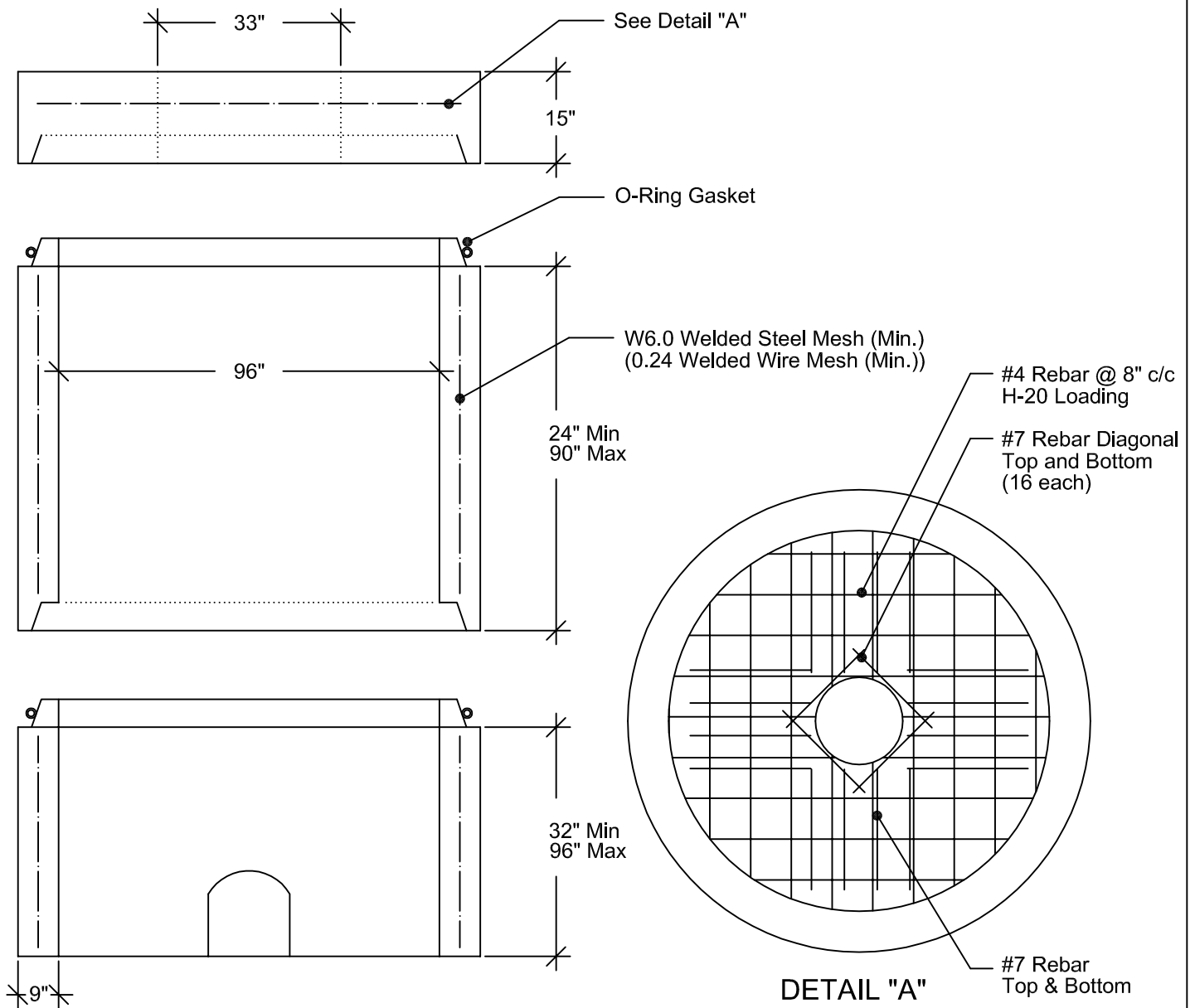

2100 NORTH 161ST E. AVE.  
 TULSA, OKLAHOMA 74116



WWW.GNCCONCRETEPRODUCTS.COM

OFC: (918) 438-1182  
 FAX: (918) 438-1185