

Precast Concrete Manhole (72" ID) Storm Sewer (Flat Top)

SPECIFICATIONS:

Openings for inlets & outlets are made 4 inches larger in diameter than the outside diameter of the pipe & are located as required per plans.

ASTM C478
Concrete: 4000 PSI (Min.)
Approx. Wt./LinFt: 1800 Lbs.
Joint O-Ring Gasket
Steel: Grade 60

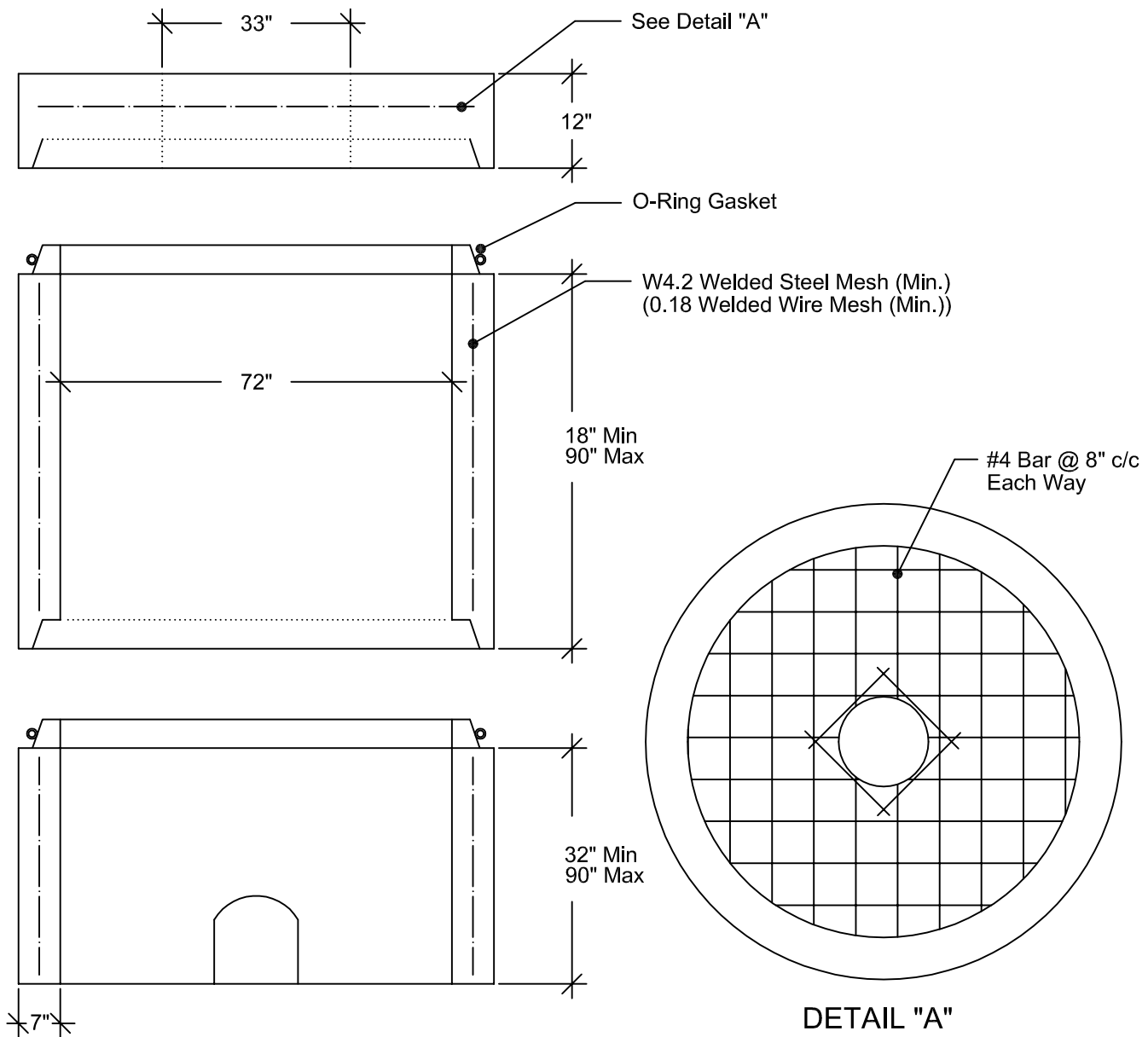

2100 NORTH 161ST E. AVE.
TULSA, OKLAHOMA 74116



WWW.GNCCONCRETEPRODUCTS.COM

OFC: (918) 438-1182
FAX: (918) 438-1185