

# Precast Concrete Air Relief Vault (48" ID) Flat Top

Openings for inlets & outlets are made 4 inches larger in diameter than the outside diameter of the pipe & are located as required per plans.

## SPECIFICATIONS:

ASTM C478  
Concrete: 4000 PSI (Min.)  
Approx. Wt./LinFt: 870 Lbs.  
Joint O-Ring Gasket

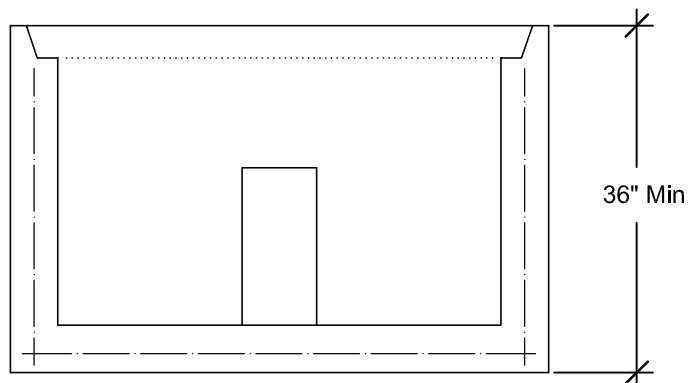
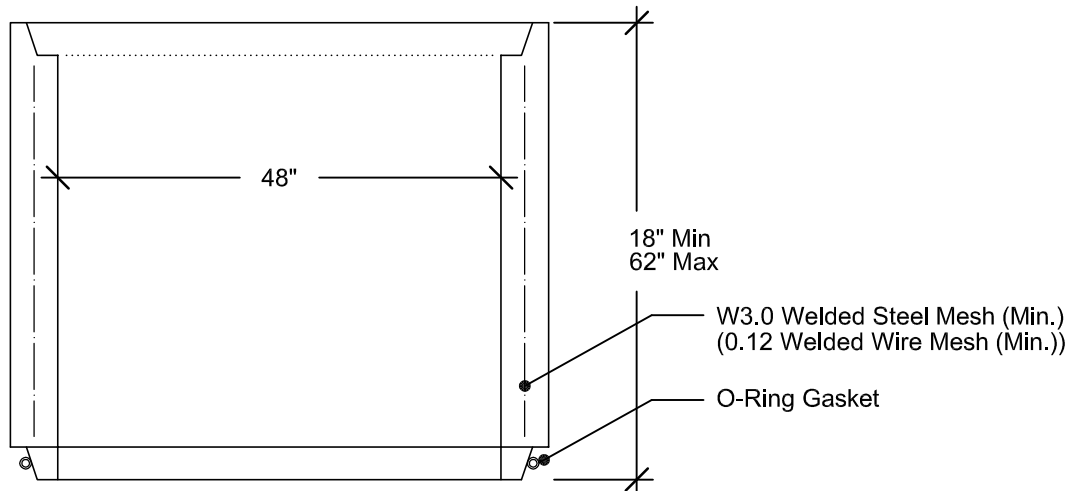
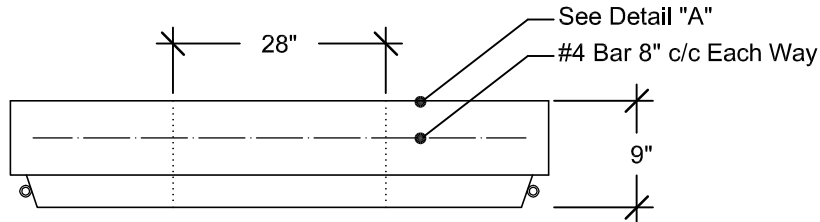

Trough in invert to be left 1 in below Flow.  
Feathered to flow by contractor.

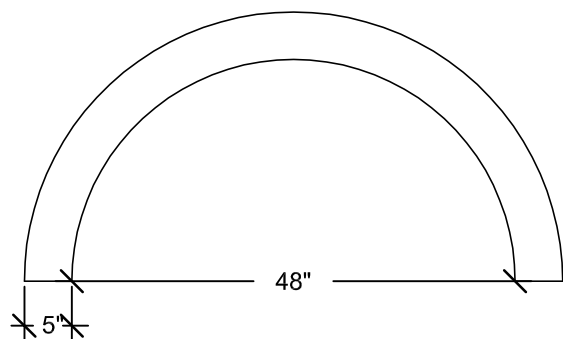

2100 NORTH 161ST E. AVE.  
TULSA, OKLAHOMA 74116 WWW.GNCCONCRETEPRODUCTS.COM

OFC: (918) 438-1182  
FAX: (918) 438-1185