

Manhole Ring #1296 & Cover #1940

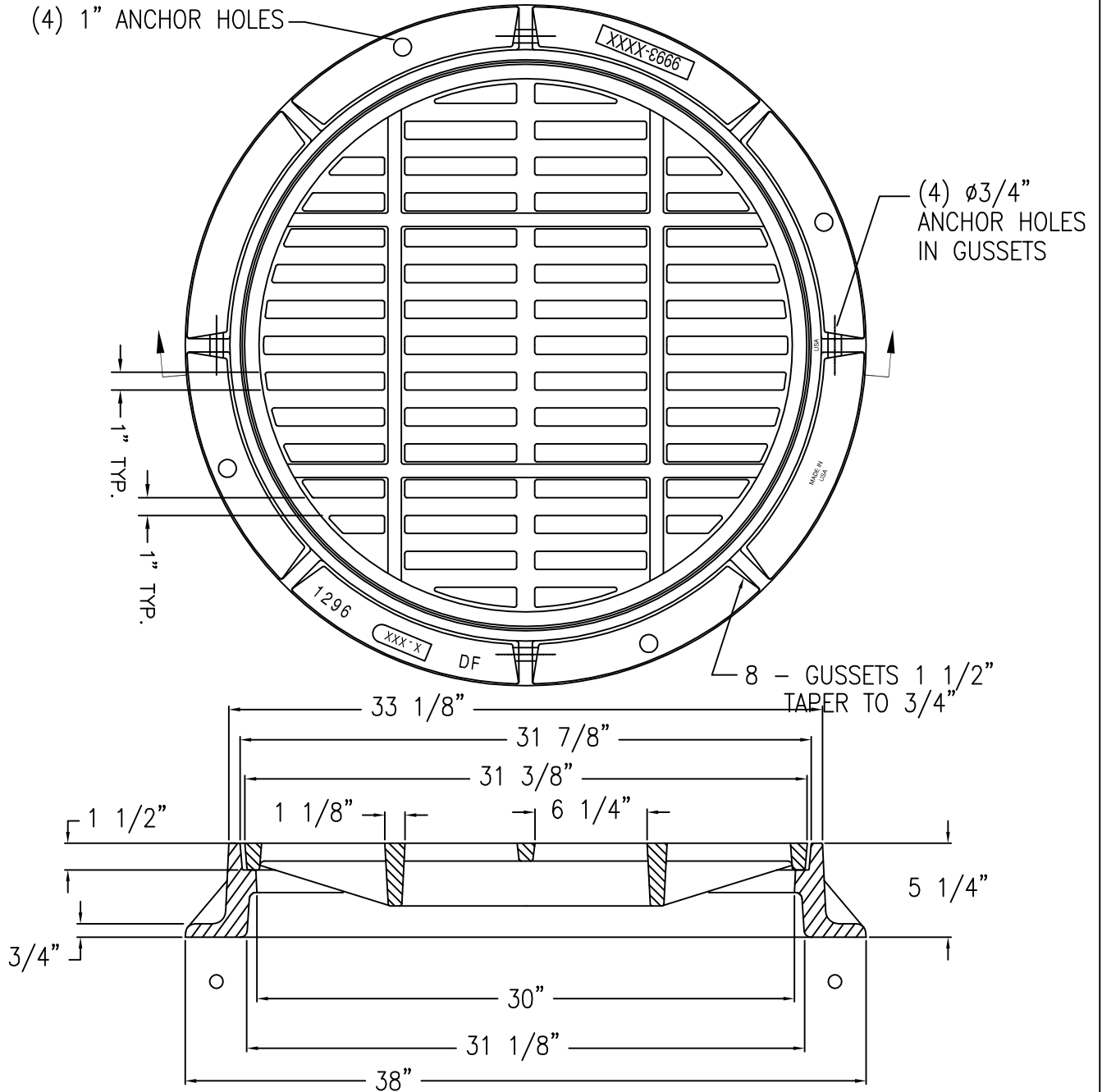

NOTE:

1. FURNISHED WITH MACHINED HORIZONTAL BEARING SURFACE.
2. OPEN AREA - 290 SQ. INCHES

MATERIAL: CAST GRAY IRON ASTM A-48, CLASS 35B

FINISH: ASPHALT PAINT

WEIGHT: FRAME 227 LBS.
GRATE 175 LBS.

 Deeter Foundry, Inc. 5945 NORTH 70th STREET LINCOLN, NEBRASKA 68529		
#1296 MANHOLE RING W/ #1940 INLET GRATE		
Date: 20 SEP 94	Drawn by: RON	Scale: 1/8
DRAWING NO. 94-1296-05	Approved by:	Date:



2100 NORTH 161ST E. AVE.
TULSA, OKLAHOMA 74116

WWW.GNCCONCRETEPRODUCTS.COM

OFC: (918) 438-1182
FAX: (918) 438-1185