

# Manhole Ring & Cover #1265

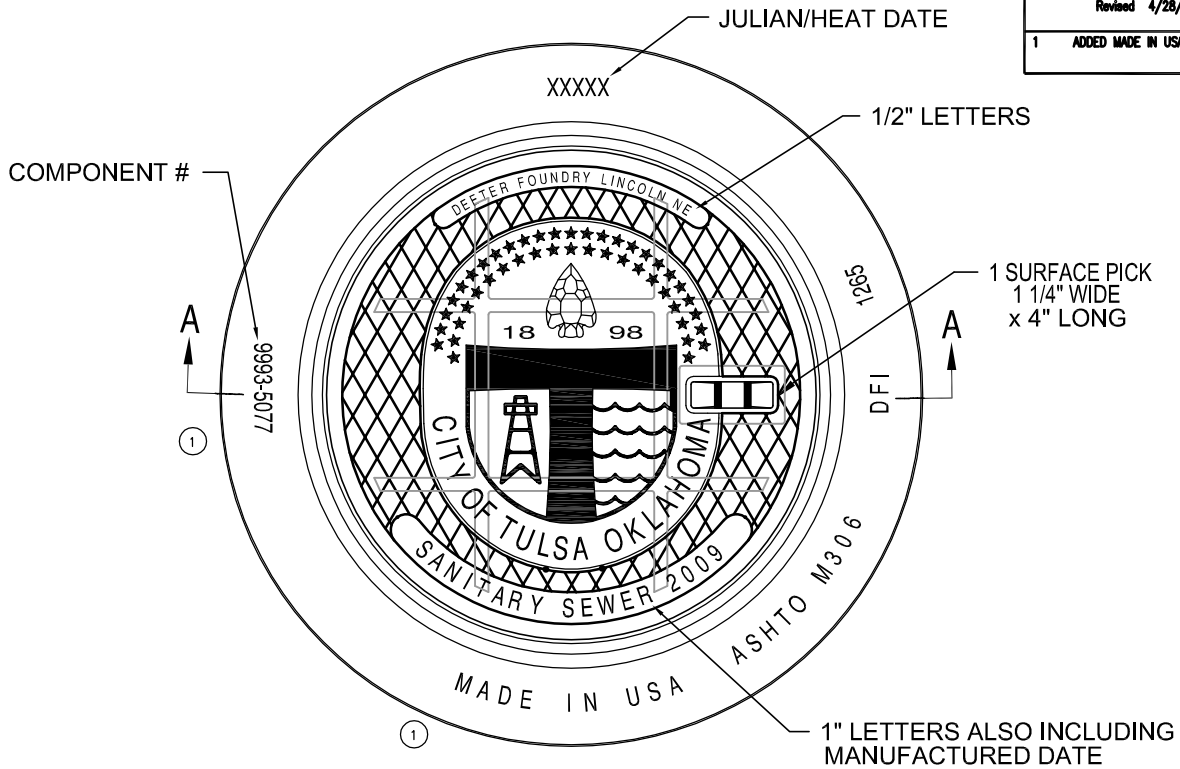

Revised 4/28/00 KRH
1 ADDED MADE IN USA, COMPONENT #

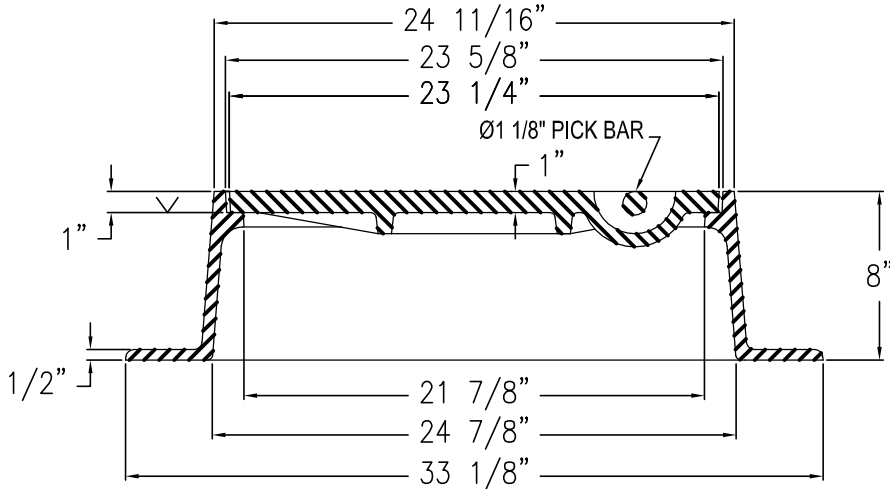

- NOTE:
1. FURNISHED WITH MACHINED HORIZONTAL BEARING SURFACES.
  2. BACK SIDE OF COVER READS: MADE IN USA, JULIAN HEAT DATE & ASHTO M306.

MATERIAL: CAST GRAY IRON ASTM A-48, CLASS 35B
FINISH: NO PAINT
WEIGHT: FRAME 160 LBS.
WEIGHT: COVER 120 LBS.

	Deeter Foundry, Inc.		
	5945 NORTH 70th STREET LINCOLN, NEBRASKA 68529		
#	1265 TUL-SAN	MANHOLE RING & COVER	
Date:	20 NOV 01	Drawn by:	KRH
Scale:	1/8		
DRAWING NO:	01-M1265-TUL-SAN	Revised by:	KRH
Date:	23 OCT 02		



2100 NORTH 161ST E. AVE.  
TULSA, OKLAHOMA 74116 WWW.GNCCONCRETEPRODUCTS.COM

OFC: (918) 438-1182  
FAX: (918) 438-1185