

Manhole Ring & Cover #1159-B

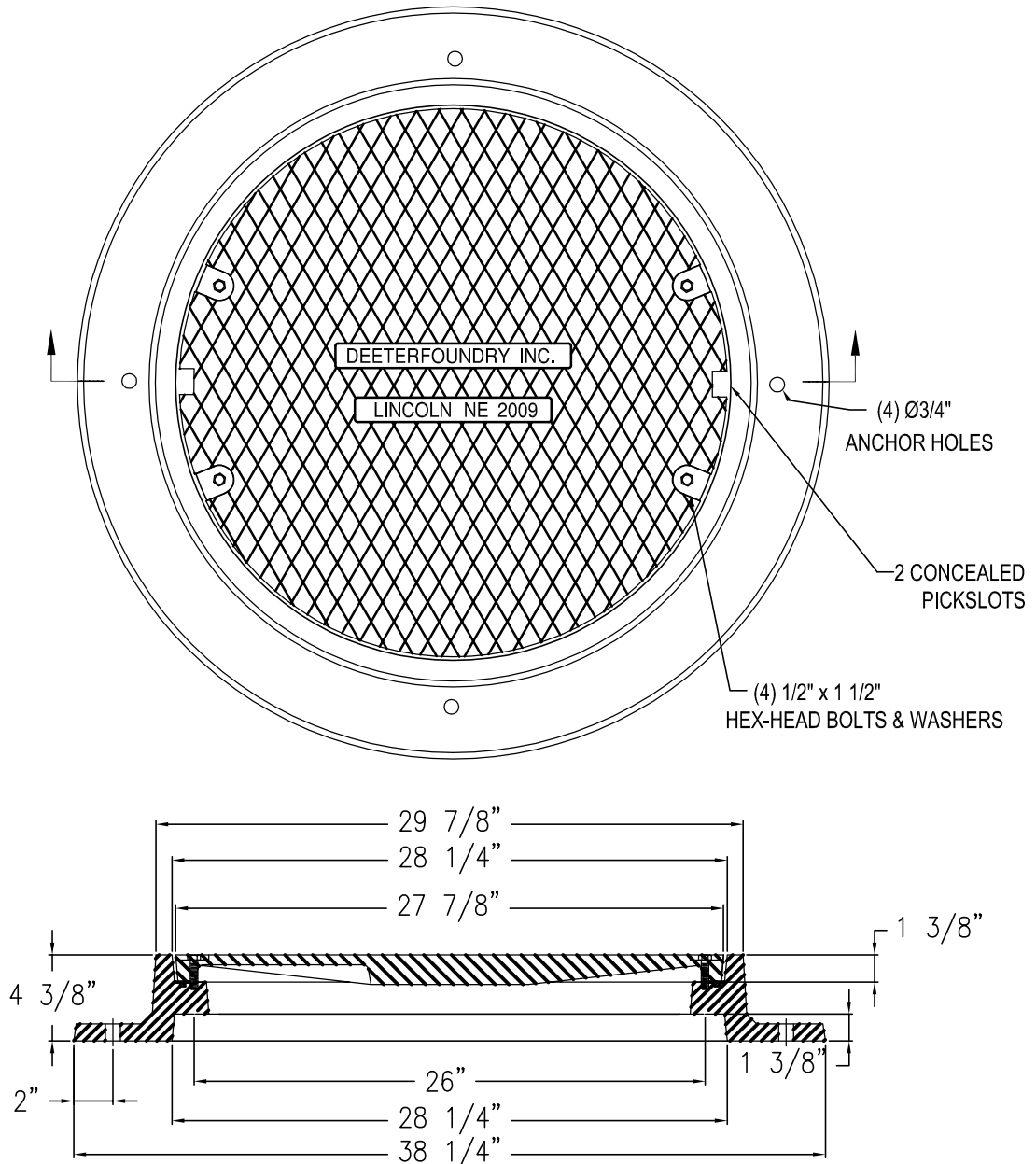

NOTE:

1. FURNISHED WITH MACHINED HORIZONTAL BEARING SURFACE.
2. FRAME IS REVERSIBLE.
3. FURNISHED WITH T-GASKET.

MATERIAL: CAST GRAY IRON ASTM A-48,
CLASS 35B

FINISH: NO PAINT

WEIGHT: 390 LBS.



Deeter Foundry, Inc.

5945 NORTH 70th STREET
LINCOLN, NEBRASKA 68529

1159B MANHOLE RING & COVER

Date: 6 MAR 96	Drawn by: DOUG	Scale: 1/8
DRAWING NO. 96-1159B-01	Approved by: KRH	Date: 19 JUNE 09



2100 NORTH 161ST E. AVE.
TULSA, OKLAHOMA 74116 WWW.GNCCONCRETEPRODUCTS.COM

OFC: (918) 438-1182
FAX: (918) 438-1185